

KRACHT

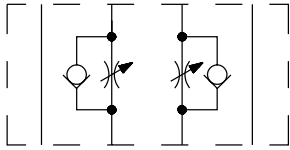

**Double throttle check valve  
2VS3-06**

# Double throttle check valve 2VS3-06



- Sandwich plate design for use in vertical stacking assemblies
- Meter-in or meter-out control as required
- Three possible arrangements
  - throttle valve in channel A
  - throttle valve in channel B
  - throttle valves in channels A and B
- Three adjustment elements
  - Installation dimensions to ISO 4401:1994
  - Subplates see Catalogue HD 0002

## Functional Description

Double throttle valves are used to control flow rates in two separate lines (A, B) of a Hydraulic circuit. The modular design provides six functional symbols. The valve body (1) has drilled channels and the throttle valve is built into channel A or B or into channels A and B. The valve restricts the fluid flow in one direction while providing reverse free-flow in the opposite direction. The throttling spool (2) is adjusted by means of a set screw (3) and each spool position corresponds with a certain passage area. Fluid entering port A1 is throttled to port A2 via groove and

an annulus area. Fluid returning from port B2 shifts the valve seat (4) against the spring (5), thus creating a passage which allows reverse free-flow to port B1 (function as check valve). The sandwich design enables simple stacking with other components of the same size. The separate O-ring plate (6) with a fitted O-rings provides sealing of the valve connecting-surface. According to the valve arrangement, the meter-in or meter-out control is provided. Changing the meter-in mode into the meter-out mode can be done by turning the valve by 180° around its horizontal axis. The orientation of the throttle

check valve in the valve body corresponds with the symbols shown on the name plate. The set screw can be operated by a key, by a hand knob or by a hand knob with keylock.

The basic surface treatment of the valve housing is phosphate coated, whereas the surfaces of the other parts are zinc coated.

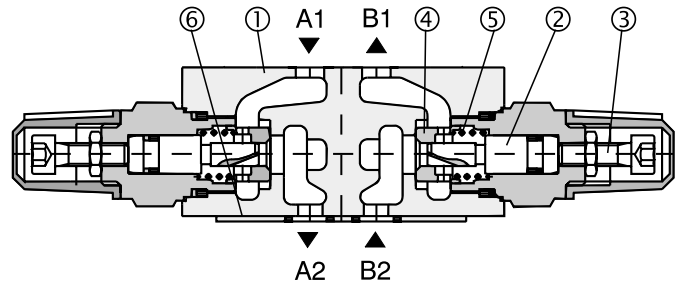

## Ordering Code

**EXAMPLE** **2VS3 - 06** - . . .

**Double throttle check valve**      **Nominal size**

**Adjustment element**

- S** Hexagon set screw with locknut and protective cap
- R** Hand knob with scale
- Z** Hand knob with scale and keylock

**Functional symbols**

**A**      **B**      **C**

① valve-side    ② subplate-side

**Note:**  
The orientation of the throttle check valve in the valve body corresponds with symbols shown on the name plate.

## Caution!

- the packing foil is recyclable
- the transport plate is to be returned to the supplier
- Mounting bolts M5x45 DIN 912-10.9 must be ordered separately. Tightening torque is 6.6 lb.ft (8,9 Nm).
- If the valve is used separately without a directional valve, a cover plate DK1-06/32-1 is to be ordered. This plate connects port A1 with B2 respectively (suitable for models 2VS3-06- Ax and 2VS3-06-Bx) - see catalogue Reduction and Cover Plates.
- The technical information regarding the product presented in this catalogue is for descriptive purposes only. It should not be construed in any case as a guaranteed representation of the product properties in the sense of the law.

## Technical Data

Nominal size:	6 mm
Maximum flow rate:	80 l/min / 21.13 US gpm
Max. operating pressure:	320 bar / 4641 psi
Hydraulic fluid:	Hydraulic oils of power classes HM, HV to CETOP RP 91 in viscosity classes ISO VG 32, 49 and 68.
Fluid temperature range:	-30... +80 °C / -22... +176 °F
Viscosity range:	10 ... 400 mm <sup>2</sup> /s
Maximum degree of fluid contamination:	Class 18/15 according to ISO 4406. Therefore we recommend a filter with retention rate $\beta_{10} \geq 75$ .
Weight:	1.2 kg / 2.65 lb
Mounting position:	optional

## Characteristics measured at $v = 35 \text{ mm}^2/\text{s}$ und $t = 40 \text{ °C}$

### Throttle valve

Pressure difference related to flow

Throttle setting in turns (from the end stop)

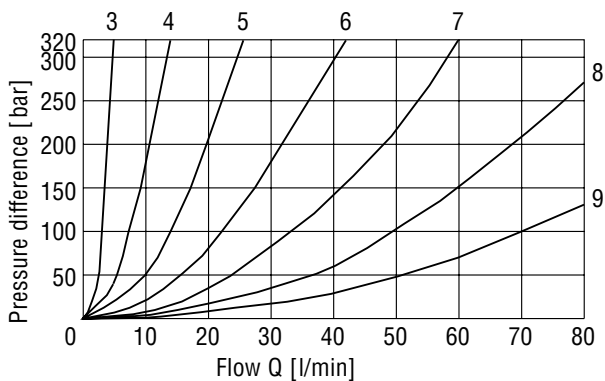

### Check valve

Pressure difference related to flow from A2 to A1, (from B2 to B1)

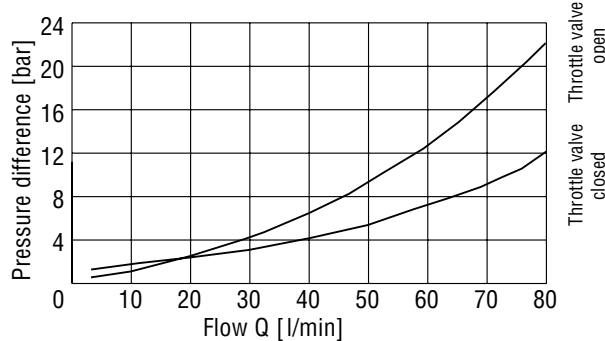

## Valve Dimensions in mm

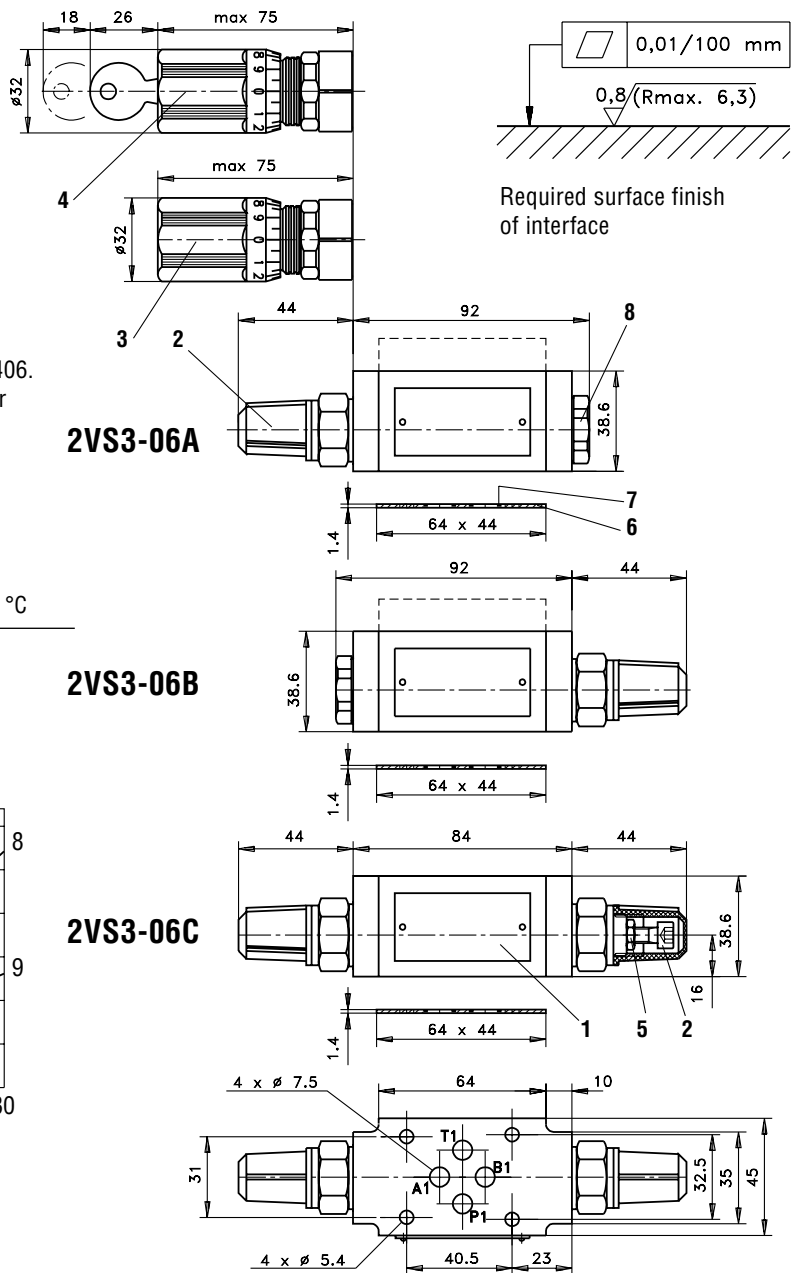

- 1 Name plate
- 2 Adjustment element – hexagon screw 5 mm with lock nut and protective cup
- 3 Adjustment element – hand knob with scale
- 4 Adjustment element – hand knob with scale and keylock  
With all adjustment elements: clockwise rotation reduces flow  
anti-clockwise rotation increases flow
- 5 Locknut (hex. 10 mm)
- 6 O-Ring plate-supplied in delivery packed
- 7 Square ring (4 pcs) supplied in delivery packed  
Standard (NBR) Square ring 9,25 x 1,68  
FKM Square ring 9,25 x 1,78
- 8 Closing screw

## Overview of our complete program

### Transfer pumps

Transfer pumps for lubricating oil supply equipment, low pressure filling and feed systems, dosing and mixing systems.

### Flow measurement

Gear and turbine flow meters and electronics for volume and flow metering technology in hydraulics, processing and laquering technology.

### Mobile hydraulics

Single and multistage high pressure gear pumps, hydraulic motors and valves for construction machinery, vehicle-mounted machines.

### Industrial hydraulics

Cetop directional control and proportional valves, hydraulic cylinders, pressure, quantity and stop valves for pipe and slab construction, hydraulic accessories for industrial hydraulics (mobile and stationary use).

With our decades of experience, we are at your side, world-wide, for the professional mastery of specific applications and complete solutions in hydraulics and process technology.



2VS3-06/e/01.05