

KRACHT

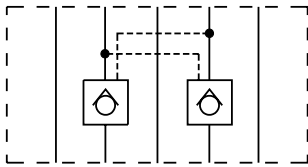

**Pilot operated check valve
VJR2-10/M**

Pilot operated check valve VJR2-10/M



- Pilot operated check valves for use in sticking assemblies
- 3 models
 - double valve with check valves in lines A and B

- single valve with check valves in line A
- single valve with check valves in line B

- Installation dimensions to ISO 4401-05-04-0-94 and DIN 24 340-A10

Functional Description

A pilot operated check valve closes tightly the hydraulic circuit between the valve and the actuator.

The valve basically consists of housing (1), one or two check valves (2), (3) and the pilot piston (4). The main poppets of the check valves are provided with pilot poppets (5) which enable opening the check valve under pressure.

When fluid flows from A1 to A2 it opens the check valve, (2) and at the same time shifts the pilot piston (4) which opens by means of the pilot poppet (5) the check valve (3). When the pressure in channels A1 and B1 drops, the springs push the poppets onto the seats and

the circuit between the check valve and the actuator is closed under pressure.

To ensure that the check valves close tightly, a directional valve with functional symbol Y is to be used, which connects in its middle position the ports A1 and B1 with tank T (see typical circuit diagram).

The basic surface treatment of the valve housing (1) is phosphate coated, whereas the other parts are zinc coated.

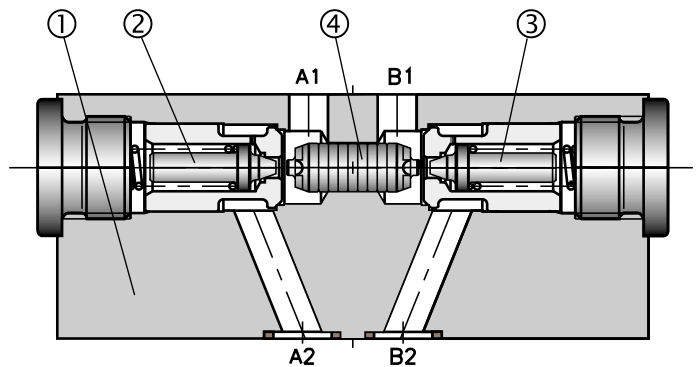

Ordering Code

EXAMPLE

VJR2 - 10 / M

Pilot operated check valve

Nominal size

Modular design

Sealing

no design V

Standard (NBR) FKM

Functional symbols

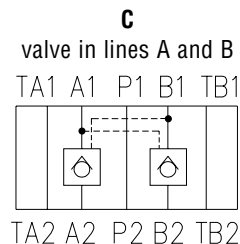
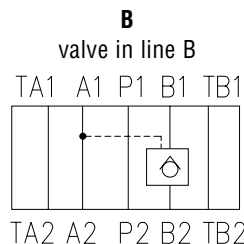
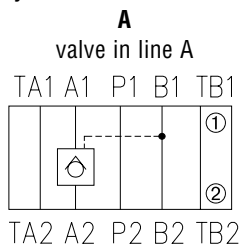

Typical circuit

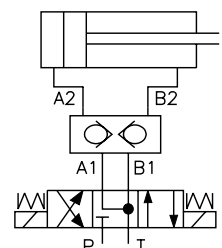

① valve-side ② subplate-side

Technical Data

Nominal size: 10 mm
 Maximum flow rate: 100 l/min / 26.42 US gpm
 Maximum operating pressure: 320 bar / 4641 psi
 Cracking pressure: 2 bar / 29 psi
 Hydraulic fluid: Hydraulic fluid of power classes HM, HV to CETOP PR 91 H in viscosity classes ISO VG 32, 46 and 68.
 Fluid temperature range for standard sealing (NBR): -30 ... +80 °C / -22 ... +176°F
 Viscosity range: 10 ... 400 mm²/s⁻¹
 Maximum degree of fluid contamination: Class 18/15 according to ISO 4406. Therefore we recommend a filter with a retention rate $\beta_{10} \geq 75$.
 Area ratio (pilot piston/ check valve seat): 5.6 : 1
 Weight: 3 kg / 6.61 lb

Δp -Q Characteristic Measured at $v = 35 \text{ mm}^2/\text{s}$ and $t = 40 \text{ °C}$

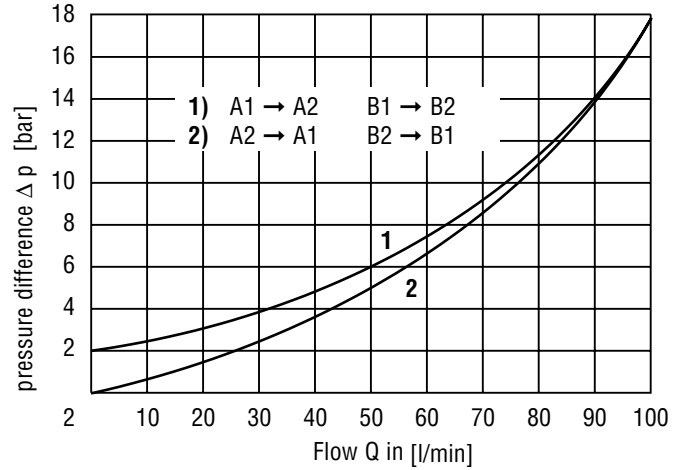

Valve Dimensions Dimensions in mm (in brackets)

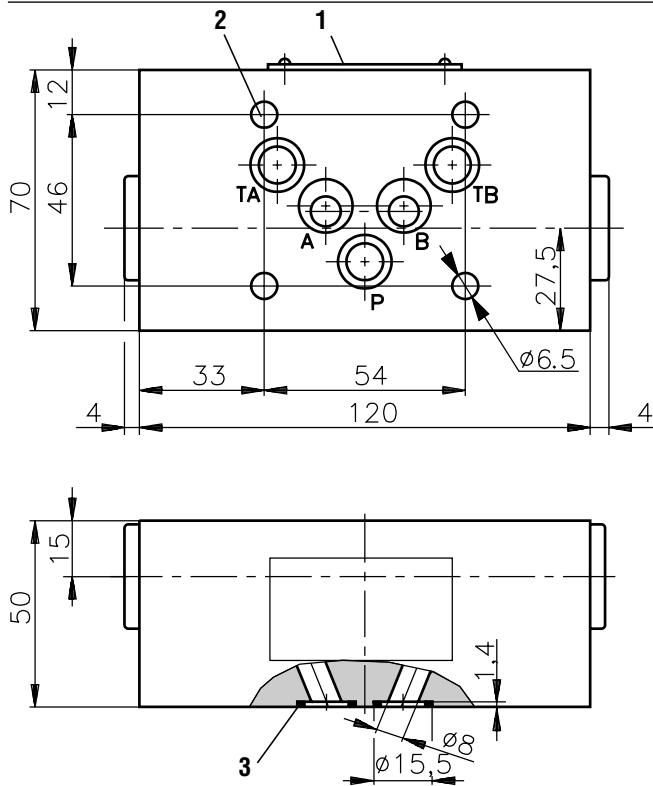

- 1 Name plate
- 2 4 mounting through-holes
- 3 Sealing rings (5 pcs) supplied in each valve
 Standard (NBR) Square ring 12,42 x 1,68
 FKM Square ring 12,42 x 1,78

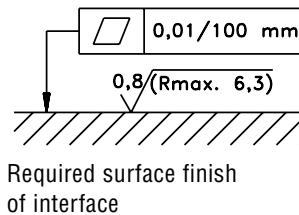

Caution!

The packing foil is recyclable. The protecting plate can be returned to the manufacturer. Tightening torque of the screws is 11.13 lb. ft (15 Nm). The technical information regarding the product presented in this catalogue is for descriptive purpose only. It should not be construed in any case as a guaranteed representation of the product properties in the sense of the law.

Overview of our complete program

Transfer pumps

Transfer pumps for lubricating oil supply equipment, low pressure filling and feed systems, dosing and mixing systems.

Flow measurement

Gear and turbine flow meters and electronics for volume and flow metering technology in hydraulics, processing and laquering technology.

Mobile hydraulics

Single and multistage high pressure gear pumps, hydraulic motors and valves for construction machinery, vehicle-mounted machines.

Industrial hydraulics

Cetop directional control and proportional valves, hydraulic cylinders, pressure, quantity and stop valves for pipe and slab construction, hydraulic accessories for industrial hydraulics (mobile and stationary use).

With our decades of experience, we are at your side, world-wide, for the professional mastery of specific applications and complete solutions in hydraulics and process technology.



VJR2-10/e/01.05